

(No Model.)

A. CRAIG & J. H. EASTMAN.  
CLOCK WINDING MECHANISM.

No. 343,947.

Patented June 15, 1886.

Fig: 1

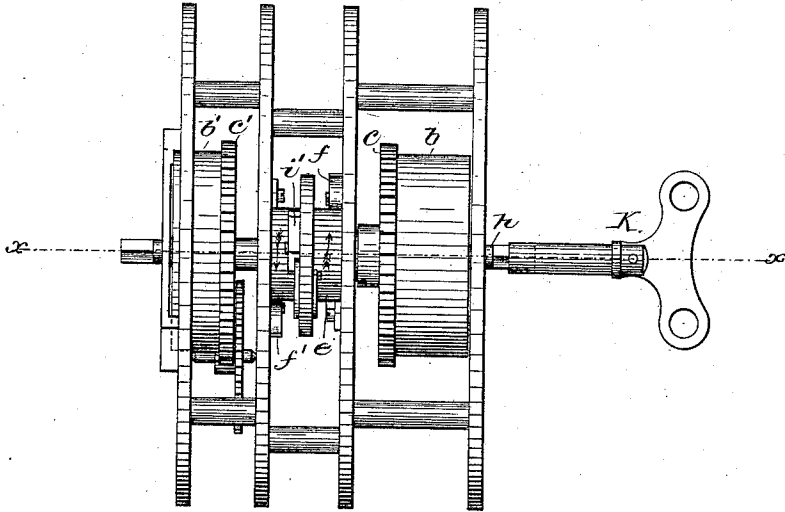

Fig: 2.

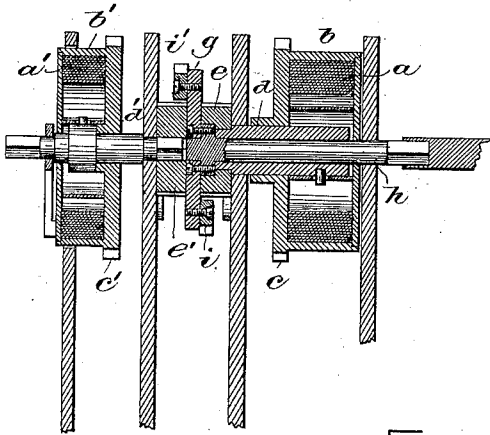

Fig: 3.

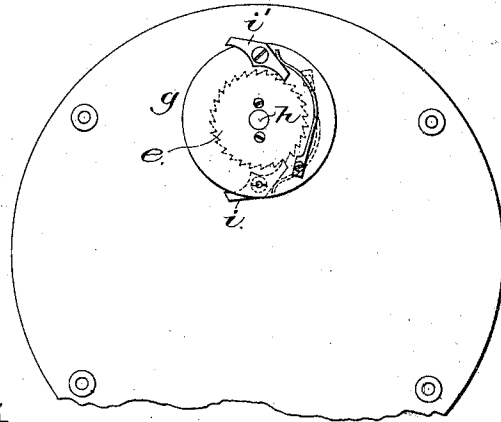
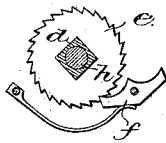

Fig: 4.



Witnesses

*Arthur Lippert.*  
*John F. C. Prinsler.*

Inventors

*Abraham Craig and*  
*Joseph H. Eastman*  
by *Corvus Gregory Atty*

# UNITED STATES PATENT OFFICE.

ABRAHAM CRAIG AND JOSEPH H. EASTMAN, OF BOSTON, MASSACHUSETTS,  
ASSIGNORS TO THE BOSTON CLOCK COMPANY, OF SAME PLACE.

## CLOCK-WINDING MECHANISM.

SPECIFICATION forming part of Letters Patent No. 343,947, dated June 15, 1886.

Application filed June 9, 1884. Renewed January 2, 1886. Serial No. 187,461. (No model.)

*To all whom it may concern:*

Be it known that we, ABRAHAM CRAIG and JOSEPH H. EASTMAN, both of Boston, county of Suffolk, and State of Massachusetts, have  
5 invented an Improvement in Clock-Winding Devices, of which the following description, in connection with the accompanying drawings, is a specification—like letters on the drawings representing like parts.

10 Our invention, relating to apparatus for winding clocks or similar mechanism, has as its object to enable two independent mainsprings or actuators for different trains of wheel-work—such, for instance, as the striking  
15 and going trains of a clock—to be wound by the movement of a single arbor actuated by a single key or equivalent.

20 Clocks have been made in which a single winding operation is sufficient for actuating both the going and striking mechanism of the clock; but in such apparatus the different mechanisms have been primarily actuated  
25 from a single mainspring, either alone or in connection with a secondary spring which is wound or strained by the said mainspring, which in either case has to be sufficiently strong to perform the entire work of both parts  
of the clock mechanism.

30 In the present invention the two trains are actuated wholly independently of one another by independent springs, and the winding mechanism is adapted to wind either of the said springs independently of the other, or to  
35 wind them both at the same operation, as may be required. The winding-shaft, which may have a key or knob attached to it, or may be squared to receive a socket-key in the usual  
40 manner, is adapted to turn in both directions, and in its movement in one direction tightens or winds one of the springs, and in the other  
45 direction winds the other spring, so that by oscillating the key back and forth, as is commonly practiced in connection with stem-winding watches, both springs will be wound  
substantially simultaneously; but by turning the said key in one direction only the corresponding spring alone will be wound.

50 As herein shown, the arbors that are connected with the ends of the mainsprings are provided with the usual ratchets, which, in connection with pawls pivoted on the frame-

work, hold the said springs, when wound, in the usual manner, and the said arbors are turned to wind the springs by pawls on a pawl-carrier or disk connected with the key-shaft, or other-  
55 wise adapted to be oscillated back and forth or turned in either direction, the ratchets of two springs being at opposite sides of the said pawl carrier, and having their teeth turned in  
60 opposite directions, so that one is engaged by the pawl-carrier when turning in one direction, and the other is engaged by the pawl-carrier when turning in the other direction. As shown, in this instance the two winding or  
65 spring arbors are in line with one another, and the key-shaft connected with the pawl-carrier passes through one of the said arbors, which is made tubular for this purpose.

70 Figure 1 is a side elevation of a clock framework having two independent mainsprings, and a winding device therefor embodying this invention, the main portion of the trains being omitted, as it forms no part of the invention; Fig. 2, a transverse section thereof on line *x x*; Fig. 3, an elevation of the pawl-carrier as seen  
75 when one of the trains, with its winding-arbor, is wholly removed, and Fig. 4 a detail to be referred to.

80 The mainspring *a*, (see Fig. 2,) inclosed in and having one end connected with a drum, *b*, and the driving-gear *c*, connected with the said drum and actuating a train of wheel-work, (not shown,) which may terminate in an escapement and actuate the hands of a clock, may all be of any usual construction,  
85 as they constitute no part of the present invention. The spring *a'*, drum *b'*, and gear *c'*, forming a portion of a separate train, may also be of usual construction, and the said train employed to actuate the striker of the  
90 clock in the usual manner. The inner end of mainspring *a* is connected with a winding-arbor, *d*, which turns loosely within the gear *c* and drum *b*, for the purpose of drawing up or winding the spring while its other end is  
95 pressing against the drum to actuate the train of wheel-work, and the said arbor *d* is provided with a ratchet, *e*, which is engaged by a retaining-pawl, *f*, on the frame-work, which thus holds the inner end of the spring *a* when  
100 wound up by rotating the arbor *d* in the usual manner. The spring *a'* is also connected with

an arbor, *d'*, provided with a ratchet, *e'*, engaged by a retaining-pawl, *f'*, on the framework, operating to wind and hold the spring *a'* in the usual manner.

5 Clocks having two independent mainsprings and trains, as thus far described, have usually had the arbors *d* and *d'* squared to receive a key, which is to be applied first to one and then to the other to wind the corresponding  
10 mainsprings or actuators, the said arbors usually being placed at opposite sides of the framework of the clock. As shown, in this instance the said arbors are placed in line with one another, and the teeth of the ratchets *e e'* are inclined in opposite directions, so that one of  
15 the said ratchets is permitted by the corresponding pawl to turn in one direction in winding the corresponding spring, while the other can turn only in the opposite direction, as indicated by the arrows thereon in Fig. 1.  
20 The ratchets *e e'* have between them a pawl-carrier, *g*, shown as a disk attached to a key-shaft, *h*, which extends through the arbor *d* of the spring *a*, the said arbor being made  
25 tubular for this purpose, and the said shaft *h* being free to turn thereon. The pawl-carrier *g* on the side adjacent to the ratchet *e* is provided with a winding-pawl, *i*, adapted to engage the teeth of the ratchet *e* when the pawl-carrier is turned in one direction, but slipping  
30 freely over the said teeth when turning in the other direction, and the said pawl-carrier is provided at its other side with another winding-pawl, *i'*, which engages the teeth of the ratchet *e'* when the said carrier is turning in  
35 the direction to permit the pawl *i* to turn over the teeth of the ratchet *e*. The relation of the pawls *i i'* are best shown in Fig. 3, in which they are seen looking from the side occupied  
40 by the ratchet *e'*, which is not shown in the said figure, the ratchet *e* being shown in dotted lines.

The operation is as follows: The arbor *h* is engaged by a key, *K*, or provided with a  
45 suitable knob or handle, by which it may be turned back and forth by the operator without letting go the said key or knob, and in its movement in one direction it will cause the pawl *i* to engage and rotate the ratchet *e*,  
50 winding the spring *a*, which is then held by the pawl *f*, while the pawl-carrier is being turned back in the other direction, during which movement it will cause the pawl *i'* to engage the ratchet *e'* and wind the spring *a'*,  
55 which is then held by the pawl *f'*.

As a person in winding a clock cannot turn his hand continuously, but has to turn it back after each fraction of a rotation, it will be  
60 seen that by the present invention this backward movement is utilized, and both springs can consequently be wound as quickly as either one alone, thus saving half the time of winding the clock; but if only one of the  
65 springs has been permitted to run down, or if for any reason it is desired to wind only one, this can be done by turning the key in the proper direction in the usual manner.

It is not essential to the invention that the two springs, with their arbors, be placed in line with one another, as shown, since an  
70 intermediate pawl-carrier may be arranged in connection with two springs when placed side by side, as in clocks of ordinary construction; and it is also not necessary that the pawl-carrier be operated by a key, as it may be oscillated  
75 back and forth by means of a projecting arm or equivalent.

For convenience in construction the ratchets *e e'* are not made integral with the arbors *d d'*, but have a squared socket for engaging  
80 them, as shown in Figs. 2 and 4, and the other end of the arbor *d'* may be squared, as shown, to facilitate the letting down of the spring when required. It is obvious that weights might be wound by similar mechanism,  
85 which would be within the scope of the present invention.

We claim—

1. The combination, with two independent springs or actuators for different independent  
90 trains of wheel-work or motors, of a winding device co-operating with each of the said actuators, as set forth, whereby both the said actuators may be wound together, or either one independently of the other, substantially as  
95 described.

2. The combination, with two independent mainsprings or actuators for independent  
100 trains of wheel-work or motors, and ratchets and pawls whereby they are retained wound up, of a winding device movable in both directions and operating to wind one of the said  
105 springs in its movement in one direction, and to wind the other in its movement in the other direction, substantially as described.

3. The combination, with two independent mainsprings or actuators, and ratchets and  
110 pawls whereby they are retained wound up, of a pawl-carrier movable in two directions, provided with two pawls, one of which engages one of the said ratchets in the movement in one direction, and the other of which  
115 pawls engages the other ratchet in the movement of the pawl-carrier in the other direction, substantially as described.

4. The combination, with two independent mainsprings or actuators, and winding-arbors  
120 therefor in line with one another, provided with ratchets, of a pawl-carrier provided with winding-pawls for engaging the said ratchets, and a winding-shaft connected with the said pawl-carrier and extended through one of the said winding-arbors, which is made tubular to receive it, substantially as described.

In testimony whereof we have signed our  
125 names to this specification in the presence of two subscribing witnesses.

ABRAHAM CRAIG.  
JOSEPH H. EASTMAN.

Witnesses:

JOS. P. LIVERMORE,  
B. J. NOYES.