

Oct. 28, 1930.

W. E. MUTZ ET AL

Des. 82,389

COMBINED SHIP BELL AND STRIKING UNIT

Filed May 29, 1930

*Fig. 2.*

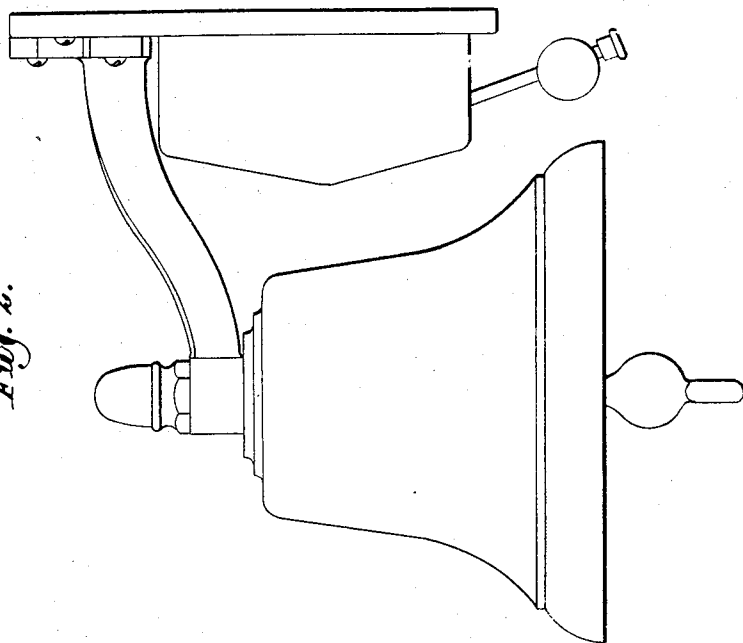

*Fig. 1.*

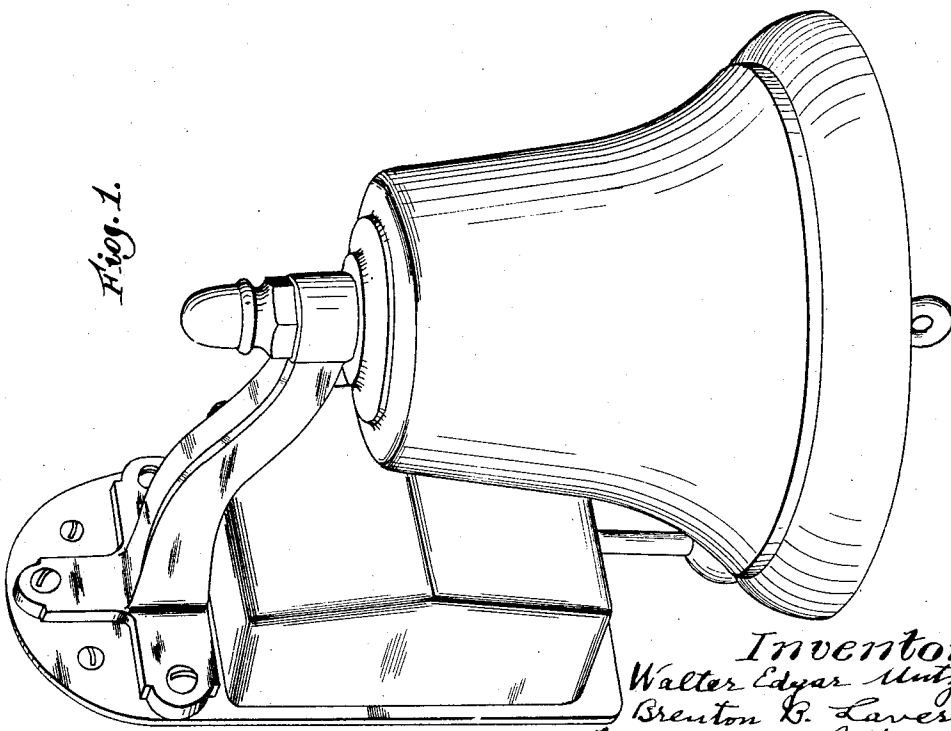

*Inventors*  
*Walter Edgar Mutz*  
*Brenton B. Lavers*  
*by James R. Hodder*  
*Attorney*

## UNITED STATES PATENT OFFICE

WALTER E. MUTZ, OF ROSLINDALE, AND BRENTON B. LAVERS, OF MEDFORD, MASSACHUSETTS, ASSIGNORS TO CHELSEA CLOCK COMPANY, OF CHELSEA, MASSACHUSETTS, A CORPORATION OF MASSACHUSETTS

DESIGN FOR A COMBINED SHIP BELL AND STRIKING UNIT

Application filed May 29, 1930. Serial No. 35,857. Term of patent 14 years.

*To all whom it may concern:*

Be it known that we, WALTER E. MUTZ of Roslindale, in the county of Suffolk, in the State of Massachusetts and BRENTON B. LAVERS, of Medford, Massachusetts, in the county of Middlesex, and both citizens of the United States, have invented a new, original, and ornamental Design for combined Ship Bell and Striking Unit, of which the following is a specification, reference being had to the accompanying drawings, forming part thereof.

Referring to the drawings:

Fig. 1 is a perspective view of the article, showing our new design.

Fig. 2 is a side view.

What we claim is:

The ornamental design for a combined ship bell and striking unit, as shown.

In witness whereof, we hereunto subscribe our names this 26th day of May, 1930.

WALTER E. MUTZ.  
BRENTON B. LAVERS.